

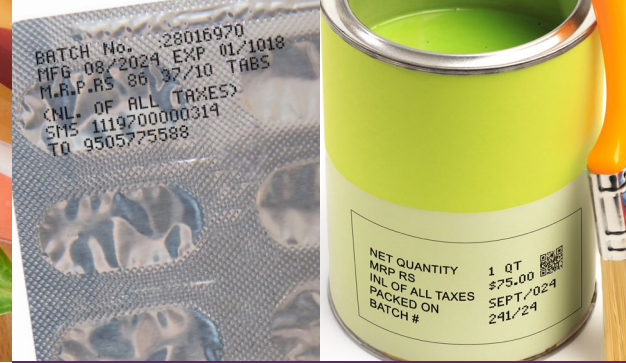

markem·imaje

a DOVER company



# Continuous inkjet 9712: The true value of innovation



## Designed to MAX your coding experience

Markem-Imaje delivers flexibility and stability with our next-generation Bi-jet model, the 9712. Backed by four-plus decades of building dependable inkjet printers, the breakthrough 9712 incorporates the best of past, present and future-proof improvements so you can adapt easily to changing marketplace needs and **code more or at a faster pace**.

Meticulously engineered and qualified by the most modern methods, the 9712's latest enhancements bring you:

- Technology leaps grounded in time-tested industrial processes for maximized uptime, reduced maintenance
- Cutting-edge design with simplified UI and modular components for easy operation, maintenance or repair
- Clear, customizable, traceable codes that meet customers' growing demand for supply chain visibility

## Key benefits

### Innovation

Advanced R&D backed by proven industrial processes and methods

- **Intelli'Inks** system ensures optimal coder performance and flexibility when coding different package materials.
- **Intelli'Swap** technology streamlines mechanicals down to swappable modules.
- **Jet Speed Control** technology automatically adjusts ink and printer variables to ensure drop placement, quality and code consistence. Every time.

### Efficiency

Prints two times faster or twice the amount of information

- **Compact print capacity** and **Bi-jet printhead properties** allow for extensive coding without altering product branding
- **Intelli'Design** process and a portfolio of rigorously developed ink formulations help reduce consumable consumption and VOC emissions by up to 50% while improving operator safety, well-being and TCO

### Digitalization

Convenience only a couple clicks away

- Remote services, including remote diagnostics, allow for a predictive analysis and therefore help maximize uptime, achieve OEE objectives
- Consumable and spare part supply through online portal
- Quick customizable 24-pin interface allows for easy integration in a 4.0 connected environment

# 9712 continuous inkjet specifications

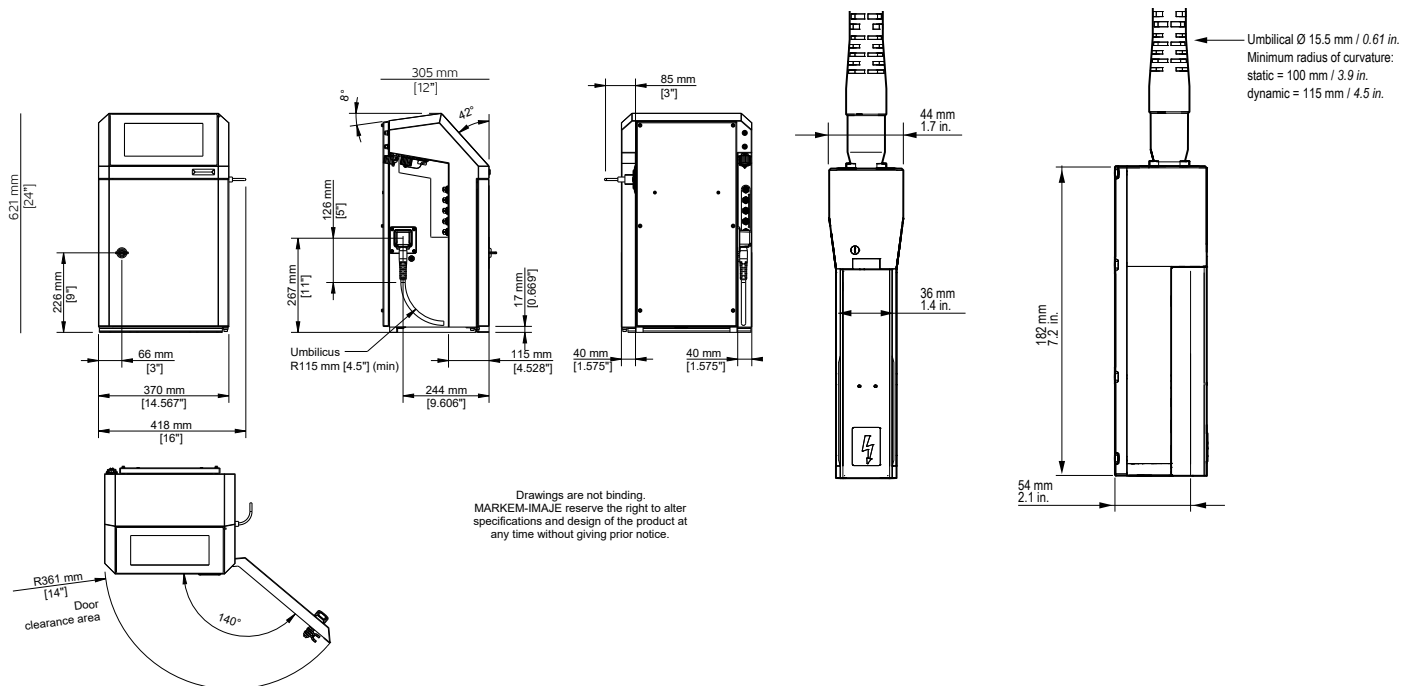

## Print features

- Bi-jet printhead
- G head (printing resolution: 71 dpi)
- Up to 8 lines of print
- Print speed: up to 4.46 m/s
- Font height from 5 to 24 dots per jet
- Character height: from 1.2 to 8.2 mm per jet
- Wide choice of 1D and 2D barcodes: EAN 8/EAN 13/UPCA /UPCE barcodes, code 39, interleaved 2 of 5, Datamatrix, QRcode, Dotcode
- Wide choice of characters: Latin, Arabic, Cyrillic, Hebrew, Japanese, Chinese, Korean, etc.

## Other characteristics

- Weight: 25 kg
- Table-top or vertical mounting
- Ultra-flexible 3-meter umbilical cable
- Stainless steel cabinet and printhead case
- Dust/water ingress protection rating: IP56 requiring no plant air
- Operating temperature range: 32 °F to 122 °F (0 °C to 50 °C) depending on ink used
- Humidity: 10 to 90% non-condensing
- Electrical power supply: 100-240 V; 1,6 A; frequency 50/60 Hz

## Operations

- WYSIWYG 7-inch capacitive touchscreen: real-time display of remaining print capacity expressed in hours and number of messages; integrated assistance and alert system; simplified message printing and management; creation of user profiles; tracking of consumption and printer availability
- Message library (up to 1,000 messages)
- Automatic selection of fonts, depending on print speed and printhead/object distance
- Specific date management (rounding date function)
- Parent/child connectivity
- Jet Speed Control guarantees marking quality
- Printhead with embedded intelligence for high marking quality and reduced maintenance
- Broad range of inks: multi-use, high performance; alcohol based, ketone-free and MEK-free inks
- Sealed 0.8-liter cartridges with fool proofing system
- Compact and modular ink circuit for better thermal management and controlled additive consumption
- 100% front access modular ink circuit for a simplified preventive maintenance
- Remote Services including our Virtual Assistant for 24/7 self-troubleshooting and "how to" videos
- Quick connect/disconnect of accessories (photocell, alarm and encoder)
- Enhanced native connectivity including USB, Ethernet, serial and a configurable M12 connector for I/O

## Options

- Ultra-flexible 2 or 6-meter umbilical cable
- Ultimate water and dust protection (plant air required)
- Printhead pressurization kit
- Many I/O possibilities including a configurable single point connector (24 pins)

## Accessories

- Wide range of accessories
- Printer supports: stands (stainless steel or aluminum), table or wall mounting brackets
- Printhead supports: stand (stainless steel) and choice of brackets
- Photocells
- Encoders
- Alarm beacons (24 V)
- Set of pre-cabled connectors M12, Ethernet IP66

## Software

- Fully compatible with CoLOS® Version 6.4 Service Pack onwards
- Logo creation with CoLOS® Graphics software

## Remote services

- Markem-Imaje Virtual Assistant for an intelligent self-support solution
- Live helpdesk support with remote video capabilities
- Connected Printer Services, based on a secured IoT cloud infrastructure\*

\* Check availability in your country



markem-imaje  
a DOVER company

9, rue Gaspard Monge - B.P. 110  
26501 Bourg-lès-Valence Cedex France  
+33 (0) 4 75 75 55 00  
[markem-imaje.com](http://markem-imaje.com)